

Fewer breakdowns, that's what it's about!



Within 30 years, NTF® has built a name for itself by developing and manufacturing housings and cartridges for the well-known Radial Micro Filtration system. Our broad and varied experience in the field of microfilters has gained us a prominent position in the industry. The NTF® Off Line Filter System, (OLFS), can be used with any hydraulic, lubrication or transmission system in virtually any market or industry. The NTF® OLFS system is equipped with its own motor-pump combination, which means that the system pressures and specifications remain in conformance with the values specified by the manufacturers. The motor-pump combination pumps oil from the reservoir (or engine sump) the dirty oil is then pumped through the filter and clean oil is returned to the reservoir.

No Leakage or Bad Pipe Connections

The NTF® Off Line Filter System is based on a modular and specially designed manifold. Because the whole system is mounted on a frame, it can be quickly and easily installed in your system. The stainless steel drip tray avoids oil spilling when the elements are changed.

At Least 10 Times More Efficient

The great advantage of NTF® Radial Micro Filters is that filtering takes place at a constant flow and at a constant pressure, making the efficiency of the NTF® bypass 10 times better than the efficiency of a standard inline filter. This results in very clean oil and fewer breakdowns. You will enjoy savings in the total cost of ownership of the system.

Reduction solid dirt particles in less then 500 hours:

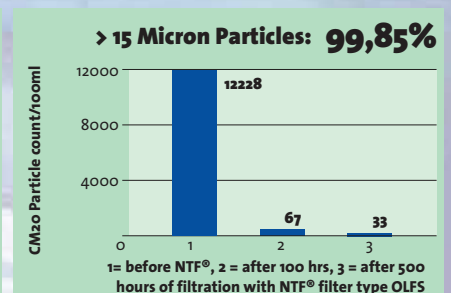
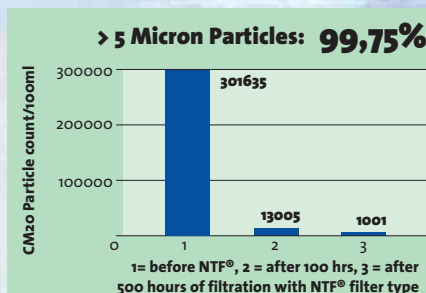
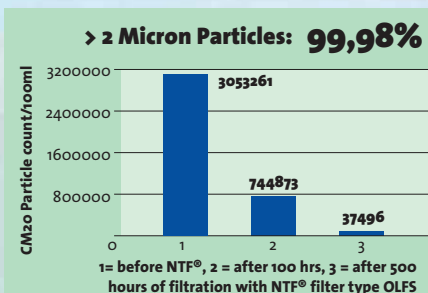

Concrete Advantages of Cleaner Oil:

- Fewer breakdowns
- Less wear and tear
- Longer oil life
- Frequency of servicing can be reduced
- Structural cost savings
- Longer service life of equipment
- Improved performance
- Environmentally friendly



Technical Specifications

Filter type	OLFS-58/6
Application	Hydraulic
Pump:	
Type	Gear pump
Displacement	- several pumps possible -
Connection suction side	1/2 BSP i.d.
Diameter suction hose	1/2 "
Seals	Buna NBR
Max. Temperature	80° Celsius
Electric motor:	
Power supply	- several tensions possible -
Norm	IEC/DIN-VDE 530
Protection rating	IP55
Filter/manifold:	
Filter efficiency	Beta (β) 4 > 10649
Dimensions filter element	Ø 78 x 600 mm (6 pcs)
Nominal flow	Depending on application
Material filter housing	Anodized aluminium
Max. pressure housing	25 Bar
Max. temperature	80° Celsius
Indicator	Press. gauge
Connection return	M22 x 1,5
I.D. Return hose	3/4 "
Seals	Buna NBR
Bypass setting	5,5 Bar
Connections monitor	1/8 BSP > M16X2
Complete unit	
Weight	90 kg approx.
Dimensions (hxwx d)	1020 x 600 x 320 mm

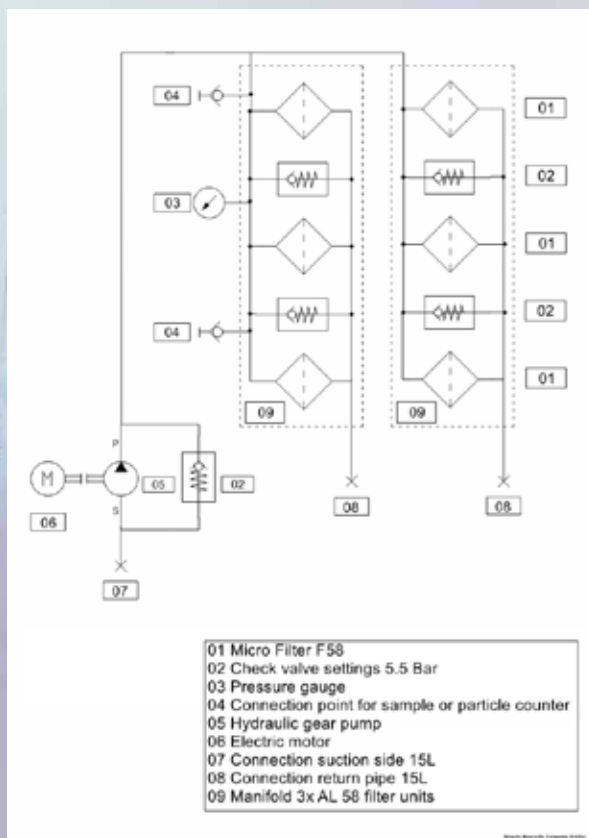

OLFS Hydraulic Scheme



NTF® Radial Micro Filters have proven their value in:

- Steel industry
- Paper industry
- Plastics industry
- Petro chemical industry
- Maritime industry
- Windmills
- Injection moulding machines
- Motor oil in ship and stationary engines
- Hydraulic aggregates

NTF® filter housings and filter cartridges can also be used in systems where manufacturers' specifications cannot be changed because of warranty conditions.

Superior filtration to improve your performance



www.ntf-filter.com

NTF FILTER B.V.

Kiotoweg 47
 3047 BG Rotterdam
 The Netherlands
 Phone: +31(0)10-3138300
 Email: info@ntf-filter.com

NTF Micro Filtration, Inc.

28221 Beck Road, Bldg A-1
 Wixom, Michigan 48393
 USA
 Phone: +1(248)449-8700
 Fax: +1(248)449-8706
 Email: info@ntf-filter.com

Dealer

